

BACHARACH
The Measurable Difference

MGS-150

Gas Detector

Installation and Operation Manual
Instruction 6309-9000
Revision 3 – August 2013



Product Leadership • Training • Service • Reliability

WARRANTY POLICY

BACHARACH, INC. WARRANTS THIS INSTRUMENT, EXCLUDING SENSORS, TO BE FREE FROM DEFECTS IN MATERIALS AND WORKMANSHIP FOR A PERIOD OF TWO YEARS FROM THE DATE OF PURCHASE BY THE ORIGINAL OWNER. THE SENSORS HAVE A WARRANTY PERIOD OF ONE YEAR FROM THE DATE OF PURCHASE. IF THE PRODUCT SHOULD BECOME DEFECTIVE WITHIN THIS WARRANTY PERIOD, WE WILL REPAIR OR REPLACE IT AT OUR DISCRETION.

THE WARRANTY STATUS MAY BE AFFECTED IF THE INSTRUMENT HAS NOT BEEN USED AND MAINTAINED PER THE INSTRUCTIONS IN THIS MANUAL OR HAS BEEN ABUSED, DAMAGED, OR MODIFIED IN ANY WAY. THIS INSTRUMENT IS ONLY TO BE USED FOR PURPOSES STATED HEREIN. THE MANUFACTURER IS NOT LIABLE FOR AUXILIARY INTERFACED EQUIPMENT OR CONSEQUENTIAL DAMAGE.

DUE TO ONGOING RESEARCH, DEVELOPMENT, AND PRODUCT TESTING, THE MANUFACTURER RESERVES THE RIGHT TO CHANGE SPECIFICATIONS WITHOUT NOTICE. THE INFORMATION CONTAINED HEREIN IS BASED ON DATA CONSIDERED ACCURATE. HOWEVER, NO WARRANTY IS EXPRESSED OR IMPLIED REGARDING THE ACCURACY OF THIS DATA.

ALL GOODS MUST BE SHIPPED TO THE MANUFACTURER BY PREPAID FREIGHT. ALL RETURNED GOODS MUST BE PRE-AUTHORIZED BY OBTAINING A RETURN MERCHANDISE AUTHORIZATION (RMA) NUMBER. CONTACT THE MANUFACTURER FOR A NUMBER AND PROCEDURES REQUIRED FOR PRODUCT TRANSPORT.

SERVICE POLICY

BACHARACH, INC. MAINTAINS AN INSTRUMENT SERVICE FACILITY AT THE FACTORY. SOME BACHARACH DISTRIBUTORS / AGENTS MAY ALSO HAVE REPAIR FACILITIES, HOWEVER, BACHARACH ASSUMES NO LIABILITY FOR SERVICE PERFORMED BY ANYONE OTHER THAN BACHARACH PERSONNEL. REPAIRS ARE WARRANTED FOR 90 DAYS AFTER DATE OF SHIPMENT (SENSORS, PUMPS, FILTERS AND BATTERIES HAVE INDIVIDUAL WARRANTIES). SHOULD YOUR INSTRUMENT REQUIRE NON-WARRANTY REPAIR, YOU MAY CONTACT THE DISTRIBUTOR FROM WHOM IT WAS PURCHASED OR YOU MAY CONTACT BACHARACH DIRECTLY.

IF BACHARACH IS TO DO THE REPAIR WORK, SEND THE INSTRUMENT, PREPAID, TO BACHARACH, INC. AT THE FOLLOWING ADDRESS.

BACHARACH, INC.
621 HUNT VALLEY CIRCLE
NEW KENSINGTON, PA 15068
ATTENTION: SERVICE DEPARTMENT

ALWAYS INCLUDE YOUR RMA #, ADDRESS, TELEPHONE NUMBER, CONTACT NAME, SHIPPING/BILLING INFORMATION AND A DESCRIPTION OF THE DEFECT AS YOU PERCEIVE IT. YOU WILL BE CONTACTED WITH A COST ESTIMATE FOR EXPECTED REPAIRS PRIOR TO THE PERFORMANCE OF ANY SERVICE WORK. FOR LIABILITY REASONS, BACHARACH HAS A POLICY OF

PERFORMING ALL NEEDED REPAIRS TO RESTORE THE INSTRUMENT TO FULL OPERATING CONDITION.

PRIOR TO SHIPPING EQUIPMENT TO BACHARACH, CONTACT OUR OFFICE FOR AN RMA # (RETURNED MERCHANDISE AUTHORIZATION). ALL RETURNED GOODS **MUST** BE ACCOMPANIED WITH AN RMA NUMBER.

PACK THE EQUIPMENT WELL (IN ITS ORIGINAL PACKING IF POSSIBLE), AS BACHARACH CANNOT BE HELD RESPONSIBLE FOR ANY DAMAGE INCURRED DURING SHIPPING TO OUR FACILITY.

NOTICES

COPYRIGHTS: THIS MANUAL IS SUBJECT TO COPYRIGHT PROTECTION; ALL RIGHTS ARE RESERVED UNDER INTERNATIONAL AND DOMESTIC COPYRIGHT LAWS. THIS MANUAL MAY NOT BE COPIED OR TRANSLATED, IN WHOLE OR IN PART, IN ANY MANNER OR FORMAT, WITHOUT THE WRITTEN PERMISSION OF BACHARACH, INC.

ALL SOFTWARE UTILIZED AND/OR DISTRIBUTED BY BACHARACH IS SUBJECT TO COPYRIGHT PROTECTION. ALL RIGHTS ARE RESERVED. NO PARTY MAY USE OR COPY SUCH SOFTWARE IN ANY MANNER OR FORMAT, EXCEPT TO THE EXTENT THAT BACHARACH GRANTS THEM A LICENSE TO DO SO. IF THIS SOFTWARE IS BEING LOADED ONTO MORE THAN ONE COMPUTER, EXTRA SOFTWARE LICENSES MUST BE PURCHASED.

TECHNICIAN USE ONLY

THIS UNIT MUST BE INSTALLED BY A SUITABLY QUALIFIED TECHNICIAN WHO WILL INSTALL THIS UNIT IN ACCORDANCE WITH THESE INSTRUCTIONS AND THE STANDARDS IN THEIR PARTICULAR INDUSTRY/COUNTRY. OPERATORS OF THE UNIT SHOULD BE AWARE OF THE REGULATIONS AND STANDARDS IN THEIR INDUSTRY/COUNTRY FOR THE OPERATION OF THIS UNIT. THESE NOTES ARE ONLY INTENDED AS A GUIDE AND THE MANUFACTURER BEARS NO RESPONSIBILITY FOR THE INSTALLATION OR OPERATION OF THIS UNIT.

FAILURE TO INSTALL AND OPERATE THE UNIT IN ACCORDANCE WITH THESE INSTRUCTIONS AND WITH INDUSTRY GUIDELINES MAY CAUSE SERIOUS INJURY INCLUDING DEATH AND THE MANUFACTURER WILL NOT BE HELD RESPONSIBLE IN THIS REGARD.

Table of Contents

Section 1. Overview	5
1.1. General Information.....	5
1.2. Technical Specifications	6
Section 2. Installation and Wiring.....	8
2.1. General Placement Guidelines	9
2.2. Components and Access Overview	9
2.3. Machinery Rooms	12
2.4. Refrigerated Spaces	14
2.5. Chillers.....	14
2.6. Air Conditioning (Direct Systems VRF/VRV)	15
2.7. Remote Sensor Head Installation.....	16
Section 3. Housing Dimensions	17
Section 4. Operation and Stabilization	21
Section 5. Configurations	22
5.1. Overview	22
5.2. Adjusting the Alarm Set Point	22
Section 6. Functional Tests and Calibration	23
6.1. Introduction	23
6.2. Bump Testing	25
6.3. Calibration Overview.....	28
6.4. Calculating Calibration Voltage	29
6.5. Calibrating Semiconductor (SC) Sensors	29
6.6. Calibrating Electrochemical (EC) Sensors.....	30
6.7. Calibrating Infrared (IR) Sensors	30
Section 7. Troubleshooting.....	31
CE Declaration of Conformity	32

Section 1. Overview

1.1. General Information

The MGS-150 is a state-of-the-art fixed gas detector which can detect a wide range of different gases. The gas sensors can be used on a stand-alone basis or integrated into Controls or Building Management Systems (BMS).

The MGS-150 can be used:

- in new buildings/areas that require continuous monitoring with high tech gas sensor transmitters.
- to add gas detection solutions to an existing system.

Typical detection applications include the detection of:

- refrigerant gases
- combustible gases
- toxic gases and/or volatile organic compounds.

The MGS Controller is an optional device used to remotely monitor up to six MGS-150 devices. For more information, refer to the MGS Controller manual (P/N 6709-9000).

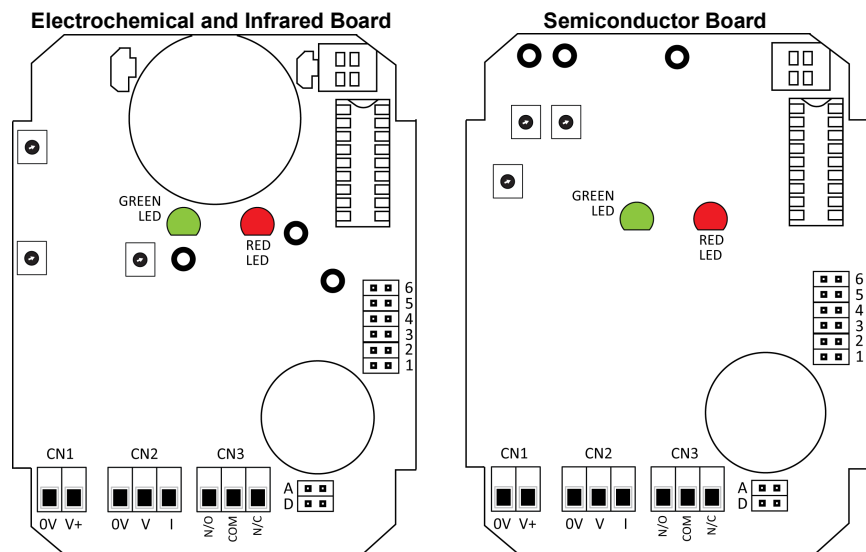

Figure 1. MGS-150 Sensor Board (EC, IR, and SC)

1.2. Technical Specifications

Specification		Description		
Power Supply	12-24 VDC, 12-24 VAC 50/60 Hz, 2 W max. Power consumption (12V): 60mA (EC), 153mA (SC), 136mA (IR)			
Monitoring LEDs	Power: Green LED	Alarm: Red LED		
Audible Alarm	Buzzer, enable/disable			
Analog Outputs	4-20 mA; 0-5 V; 0-10 V; 1-5 V; 2-10 V			
Relay Outputs	1 relay rated 1 A @ 24 VAC/VDC; Delay: 0, 1, 5, or 10 minutes			
IP Rating	IP41 (standard); IP66 (optional)			
Temperature Rating	Sensor	IP41 Housing	IP66 Housing	
	IR and SC (all)	-4° to 122° F (-20° to 50° C)	-40° to 122° F (-40° to 50° C)	
	EC (all but NH ₃)	-4° to 104° F (-20° to 40° C)	-4° to 104° F (-20° to 40° C)	
	EC (NH ₃)	-4° to 104° F (-20° to 40° C)	-40° to 104° F (-40° to 40° C)	
Humidity Rating	0-95% non-condensing			
Dimensions/ Weights per Enclosure Type (see Note below)	Housing	Dimensions	Weight	
	IP41 (standard)	3.35" x 5.59" x 2.09" 86 x 142 x 53 mm	6.3 oz 180 g	
	IP66 (optional)	6.89" x 6.5" x 3.29" 175 x 165 x 82 mm	1 lb 6 oz 629 g	
	w/ Splash Guard	6.89" x 8.9" x 3.29" 175 x 225 x 82 mm	1 lb 9 oz 700 g	
	w/ Remote Sensor	6.89" x 6.1" x 3.29" 175 x 155 x 82 mm	1 lb 11 oz 790 g	
	w/ Exd Sensor Head	6.89" x 6.1" x 3.29" 175 x 155 x 82 mm	2 lb 10 oz 1185 g	
	w/PRV Sensor Head	6.89" x 6.1" x 3.29" 175 x 155 x 82 mm	2 lb 0.3 oz 916 g	
	w/ Airflow/Duct	6.89" x 4.9" x 3.29" 175 x 125 x 82 mm	1 lb 4 oz 578 g	
	Exd (ATEX only)	5.51" x 7.09" x 3.54" 140 x 180 x 90 mm	4 lb 15 oz 2234 g	
Approvals	CE; UL/CSA/IEC/EN 61010-1			



NOTE: Enclosures listed above are for all models/configurations *except* IR Halogen, which use the standard IP41 enclosure with a different temperature rating.



NOTE: The hazardous area **EXd Gas Monitor** products are designed with individually certified EXd main housing enclosures and certified EXD remote or attached sensor enclosures. The main housing enclosure and its PCB assembly are also EXd certified, but the final **EXd Gas Monitor** assemblies (main enclosure and/or sensor assembly) are not currently EXD certified, but are pending additional testing.

Supported CFM/Duct Sizes for the Duct Mount Housing

Units		Duct Size			
Inches	12 x 12	12 x 24	18 x 18	24 x 24	24 round
Feet	1 x 1	1 x 2	1.5 x 1.5	2 x 2	Pi x 1 x 1
Area (ft ²)	1	2	2.25	4	3.14
CFM	Ft/min (Based on CFM and Duct Size)				
2800	2800	n/a	n/a	n/a	n/a
3000	3000	n/a	n/a	n/a	n/a
3400	3400	n/a	n/a	n/a	n/a
3800	3800	n/a	n/a	n/a	n/a
4000	4000	n/a	n/a	n/a	n/a
4400	4400	n/a	n/a	n/a	n/a
4800	4800	n/a	n/a	n/a	n/a
5000	5000	2500	n/a	n/a	n/a
5400	5400	2700	n/a	n/a	n/a
5800	5800	2900	2578	n/a	n/a
6000	6000	3000	2667	n/a	n/a
6400	6400	3200	2844	n/a	n/a
6800	6800	3400	3022	n/a	n/a
7000	7000	3500	3111	n/a	n/a
7400	7400	3700	3289	n/a	n/a
7800	7800	3900	3467	n/a	n/a
8000	8000	4000	3556	n/a	2548
8400	8400	4200	3733	n/a	2675
8800	8800	4400	3911	n/a	2803
9000	9000	4500	4000	n/a	2866
9400	9400	4700	4178	n/a	2994
9800	9800	4900	4356	n/a	3121
10000	10000	5000	4444	2500	3185

Section 2. Installation and Wiring



WARNING: Explosion hazard! Do not mount the MGS in an area that may contain flammable liquids, vapors, or aerosols. Operation of any electrical equipment in such an environment constitutes a safety hazard.



CAUTION: The MGS contains sensitive electronic components that can be easily damaged. Do not touch nor disturb any of these components.



NOTE: The mounting location of the monitor should allow it to be easily accessible for visual monitoring and servicing.



NOTE: The monitor must be connected by a marked, suitably located and easily reached switch or circuit-breaker as means of disconnection.



NOTE: Connect monitor power and signaling terminals using wiring that complies with local electrical codes or regulations for the intended application.



NOTE: This instrument can be equipped with a semiconductor sensor for the detection of refrigerant, combustible and VOC gases. Semiconductor sensors are not gas specific and respond to a variety of other gases including propane exhaust, cleaners, and solvents. Changes in temperature and humidity may also affect the sensor's performance.

2.1. General Placement Guidelines



NOTE: The MGS-150 should be installed plumb and level and securely fastened to a rigid mounting surface.

Sensors must be located within the appropriate wire lengths from the central control unit (if used).

In all cases the sensor supplied is designed for maximum sensitivity to a particular gas. However, in certain circumstances false alarms may be caused by the occasional presence of sufficiently high concentrations of other gaseous impurities. Examples of situations where such abnormalities may arise include the following:

- Plant room maintenance activity involving solvent or paint fumes or refrigerant leaks.
- Accidental gas migration in fruit ripening/storage facilities (bananas - ethylene, apples - carbon dioxide).
- Heavy localized exhaust fumes (carbon monoxide, dioxide, propane) from engine-driven forklifts in confined spaces or close to sensors.

Bacharach recommends setting the alarm delay to minimize false alarms.

2.2. Components and Access Overview



NOTE: The wiring is the same for the electro-chemical, semi-conductor, and infrared models. The controller wiring is the same for all controllers.

There is a 5-minute power-up delay to allow the sensor to stabilize. Refer to Figure 2 and Figure 3 for internal components and wiring.

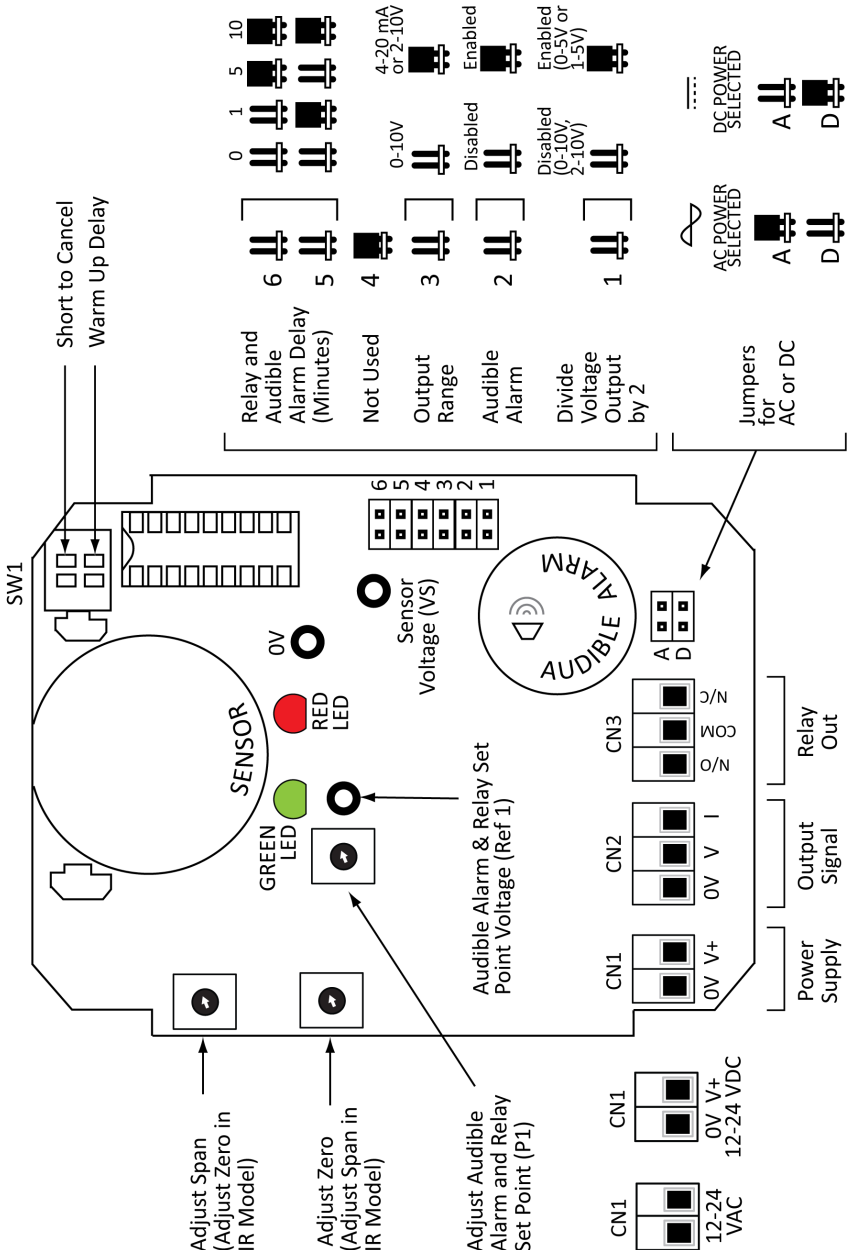

Figure 2. EC or IR Sensor Components and Wiring

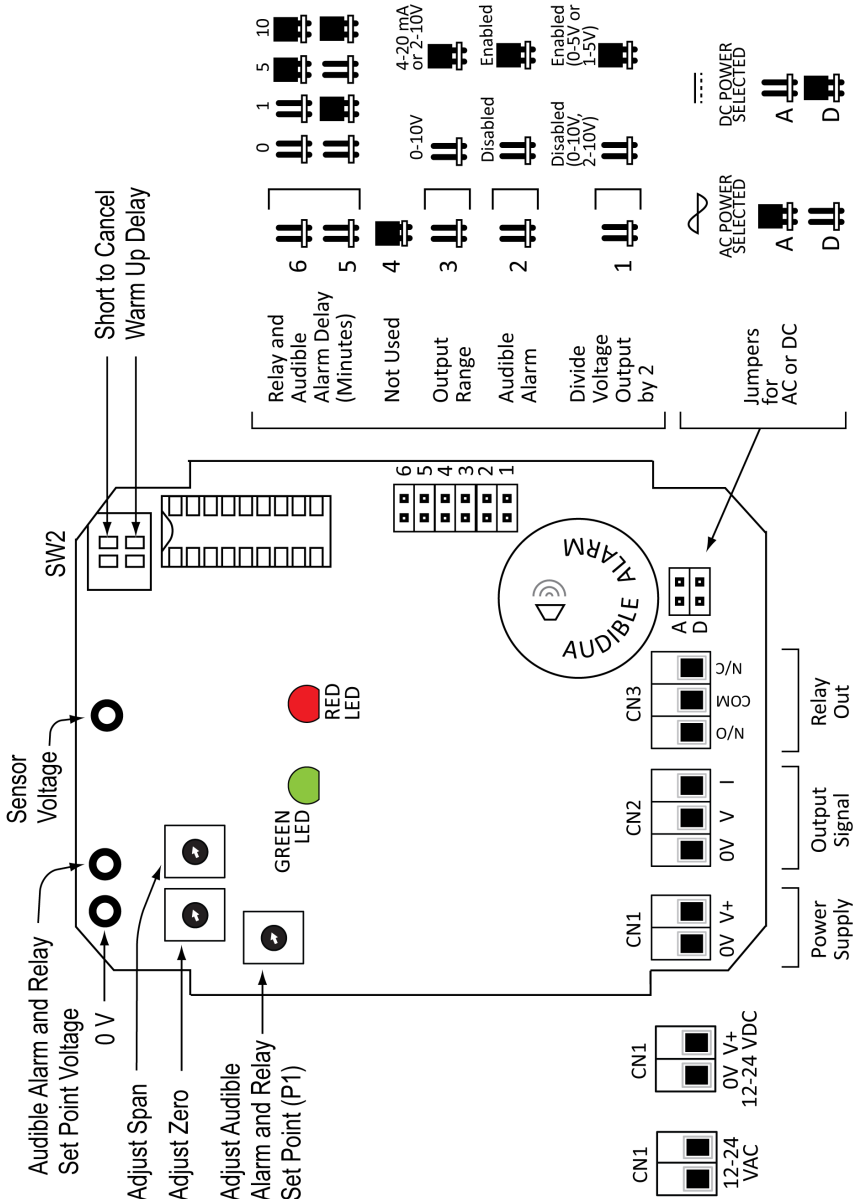

Figure 3. SC Sensor Components and Wiring

Item	Description
Enclosure Access	To open the standard sensor enclosure, turn the cable clamp 1/2 turn counter-clockwise to loosen the internal gland nut, depress the clip on top of the enclosure and open. Reverse to close. (Note: For the IP66 enclosure, use the four bolts on the front cover.)
Power	12-24V AC/DC, connect at positions 0V and +V at connector block CN1. <ul style="list-style-type: none"> • For AC: Jumper A is on, D is off. (See Figure 2 and Figure 3. • For DC: Jumper A is off, D is on. (Default factory setting is DC.) Use 2 wires, typically 18 AWG (minimum).
Output	Connect two wires to terminal block CN2 positions 0V and V or I for voltage or current, respectively. <ul style="list-style-type: none"> • Connect 4-20mA at CN2 positions 0V and I • Connect voltage output at CN2 positions 0V and V
Relay Set Point	P1 sets the trip point for the relay and audible alarm using the 0- 5V scale (measure at test points 0V and alarm test point TP1). Default factory setting is 50% of the range.
Time Delay	A time delay for the operation of the relay and audible alarm can be selected using jumpers JP5 and JP6. Default factory setting is zero.
Audible Alarm	The audible alarm can be disabled using jumper JP3. Default factory setting is enabled.

2.3. Machinery Rooms

There is no absolute rule in determining the number of sensors and their locations. However, a number of simple guidelines will help to make a decision. Sensors monitor a point as opposed to an area. If the gas leak does not reach the sensor then no alarm will be triggered. Therefore, it is extremely important to carefully select the sensor location. Also consider ease of access for maintenance.

The size and nature of the site will help to decide which method is the most appropriate to use. Locations requiring the most protection in a machinery or plant room would be around compressors, pressurized

storage vessels, refrigerant cylinders or storage rooms or pipelines. The most common leak sources are valves, gauges, flanges, joints (brazed or mechanical), filling or draining connections, etc.

- When **mechanical or natural ventilation** is present, mount a sensor in the airflow.
- In machinery rooms where there is **no discernable or strong airflow** then options are:

Point Detection, where sensors are located as near as possible to the most likely sources of leakage, such as the compressor, expansion valves, mechanical joints or cable duct trenches.

Perimeter Detection, where sensors completely surround the area or equipment.

- For **heavier-than-air gases** such as halocarbon and hydrocarbon refrigerants such as R404A, propane, and butane sensors should be located near ground level.
- For **lighter-than-air gas** (e.g., ammonia), the sensor needs to be located above the equipment to be monitored on a bracket or high on a wall within 12 in (300 mm) of (or on) the ceiling – provided there is no possibility of a thermal layer trapped under the ceiling preventing gas from reaching the sensor.



NOTE: At very low temperatures (e.g., refrigerated cold store), ammonia gas becomes heavier than air.

- With similar density or miscible gases (e.g., CO or CO₂), sensors should be mounted about head high (about 5 ft [1.5 m]).
- Sensors should be positioned just far enough back from any high-pressure parts to allow gas clouds to form and be detected. Otherwise, a gas leak might pass by in a high-speed jet and not be detected by the sensor.
- Make sure that pits, stairwells and trenches are monitored since they may fill with stagnant pockets of gas.
- If a pressure relief vent (PRV) pipe is fitted to the system, it may be a requirement to mount a sensor to monitor this vent pipe. It could be positioned about 6 feet (2 m) above the PRV to allow gas clouds to form.
- For racks or chillers pre-fitted with refrigerant sensors, these should be mounted so as to monitor the compressors. If extract ducts are fitted the airflow in the duct may be monitored.

2.4. Refrigerated Spaces

In refrigerated spaces, sensors should be located in the return airflow to the evaporators on a sidewall (below head-high is preferred), or on the ceiling, not directly in front of an evaporator. In large rooms with multiple evaporators, sensors should be mounted on the central line between 2 adjacent evaporators, as turbulence will result in airflows mixing.

2.5. Chillers

In the case of small water- or air-cooled enclosed chiller units mount the sensor so as to monitor airflow to the extract fans. With larger models also place a sensor inside the enclosure under or adjacent to the compressors.

In the case of outdoor units:

- For enclosed air-cooled chillers or the outdoor unit for variable refrigerant volume and variable refrigerant flow (VRV/VRF) systems, mount the sensor so as to monitor airflow to the extract fan. With large units also place a sensor inside the enclosure under or adjacent to the compressors.

In the case of non-enclosed outdoor units:

- If there is an enclosed machinery section locate a sensor there.
- In the case of units with enclosed compressors, mount sensors in the enclosures.
- Where you have protective or acoustic panels mount the sensor low down under the compressors where it is protected by the panels.
- With air-cooled chillers or air-cooled condensers with non-enclosed condenser sections it is difficult to effectively monitor leaks in the coil sections. With some designs it will be possible using an airflow sensor to monitor airflow to the start-up fans in the front or rear sections.
- If there is a possibility of refrigerant leaks into a duct or air-handling unit install a sensor to monitor the airflow.

Weatherproof sensors should be used for unprotected outdoor applications.

2.6. Air Conditioning (Direct Systems VRF/VRV)

For compliance with EN378, at least one detector shall be installed in each occupied space being considered and the location of detectors shall be chosen in relation to the refrigerant and they shall be located where the refrigerant from the leak will collect. In this case refrigerants are heavier than air and detectors should have their sensors mounted low, e.g., at less than bed height in the case of an hotel or other similar Category Class A spaces. Ceilings or other voids if not sealed are part of the occupied space.



CAUTION: Monitoring ceiling voids in a hotel room would not strictly comply with EN378.

Do Mount In-Room Sensors...	Don't Mount Sensors...
...at less than the normal heights of the occupants. E.g., in a hotel room this is less than bed height (between 8 and 20 inches [200 and 500 mm] off the floor).	...under mirrors.
...away from drafts and heat sources like radiators, etc.	...at vanity units.
... to avoid sources of steam.	...in or near bathrooms.

2.7. Remote Sensor Head Installation

If you do not wish to surface mount the MGS, a brushed stainless steel faceplate is available. The remote sensor is mounted in an electrical back box 1.7 in (44 mm) deep to which the vented faceplate is fitted.



CAUTION: To avoid component mix-up, do not remove sensor boards from multiple units at the same time. Alternatively, label them, or match the serial number on the main PCB and the remote sensor PCB when reinstalling.

1. Remove the connector from the sensor PCB to feed the cable through the housing.
2. Immediately refit the connector to the sensor board in the back of the box. The MGS and remote sensor must be kept together as they are calibrated together and are a matched pair.

To clean, the faceplate should be lightly dusted.



IMPORTANT: Do not spray the MGS-150 with cleaning or polishing aerosols.

Section 3. Housing Dimensions

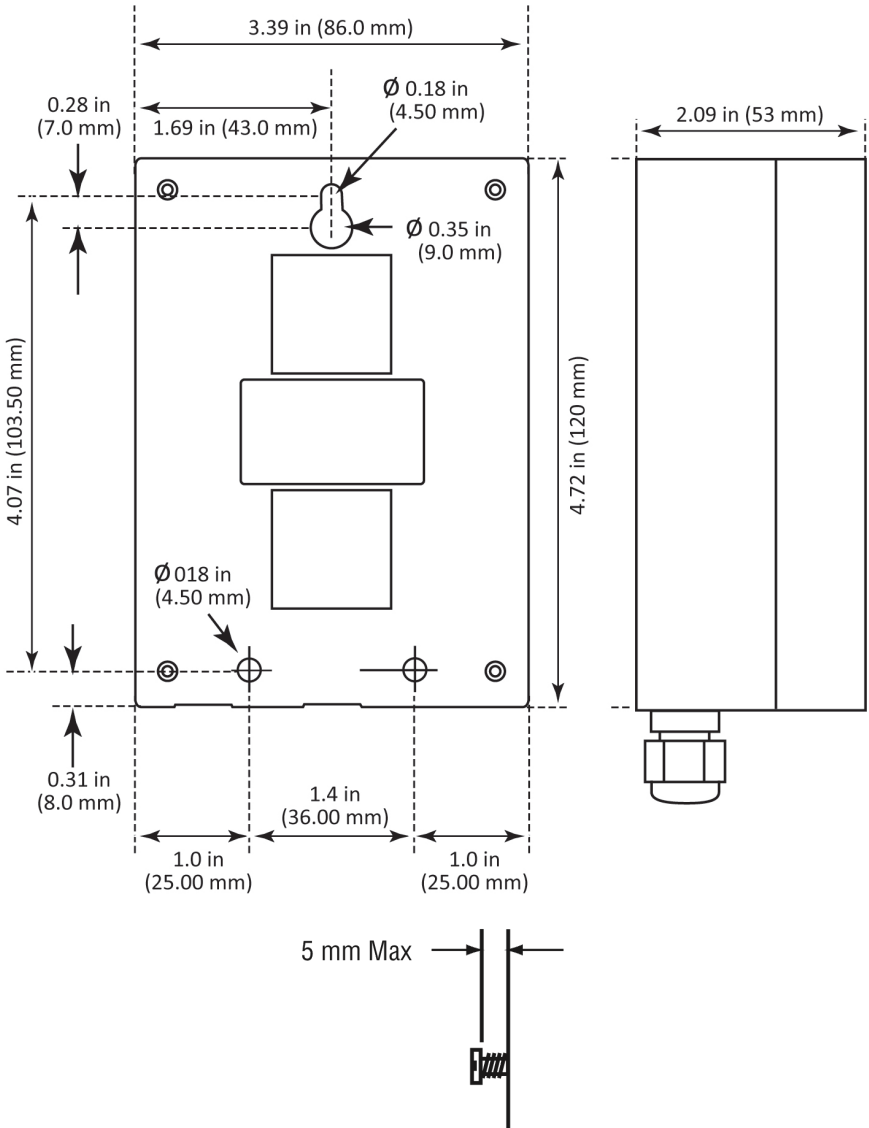

Figure 4. MGS-150 Standard Housing

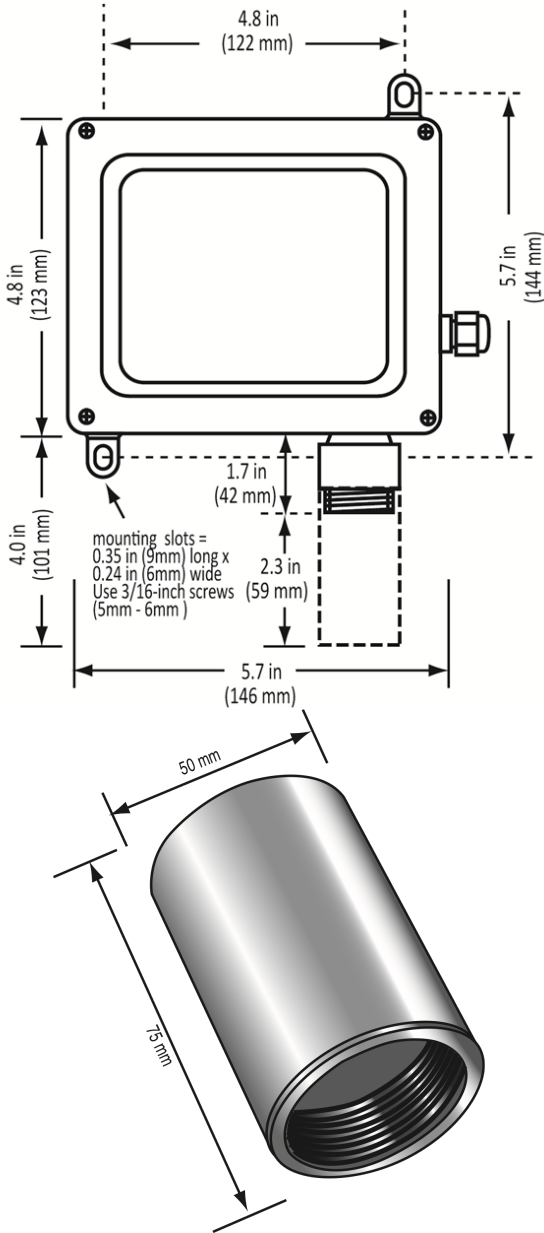

Figure 5. IP66 Housing with Splashguard

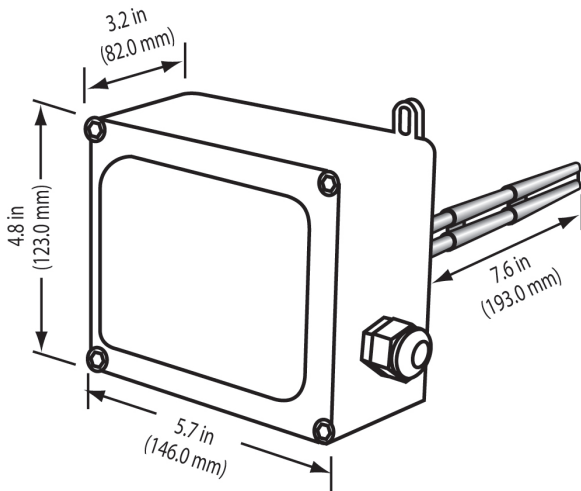

Figure 6. IP66 Airflow Duct Mount Housing

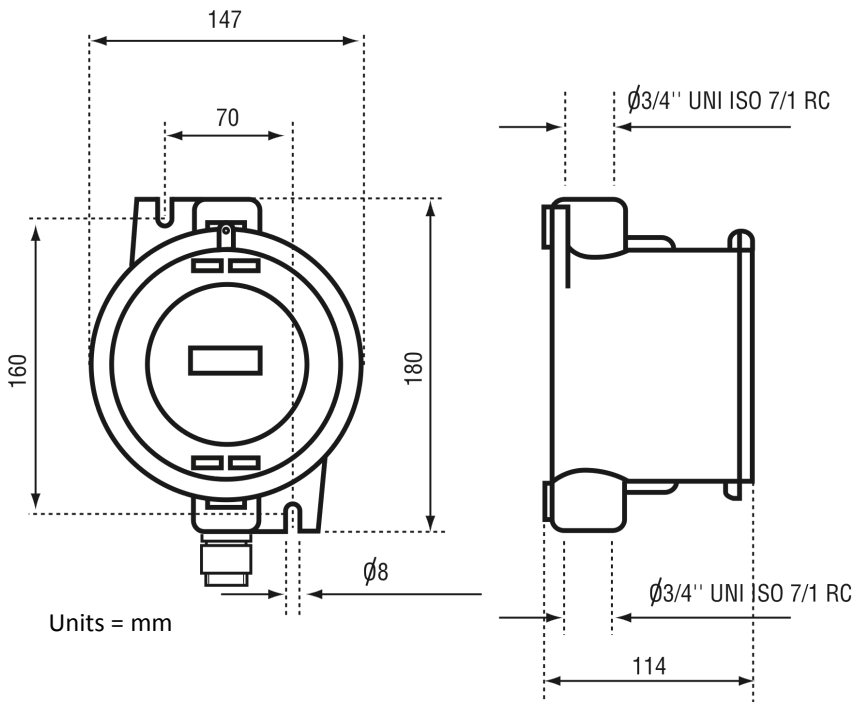
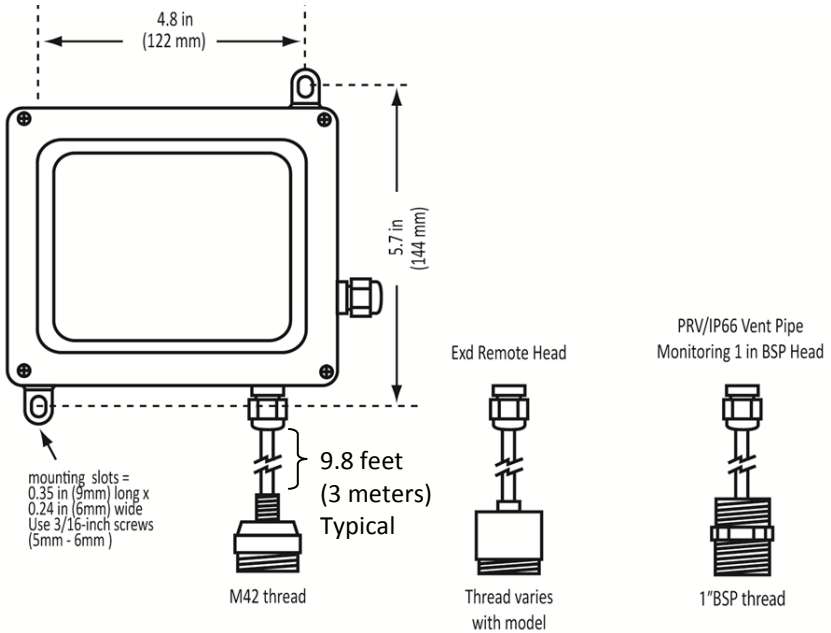

Figure 7. Exd Housing



For Dimensions and Mounting Locations , See Figure 5.

Figure 8. IP66 Housing with Remote Sensor Head



NOTE: For the Exd Remote Sensor Head and 16.4 ft (5 m) cable, the thread varies based on the model.

Section 4. Operation and Stabilization

On powering up, the MGS-150 will sense for the presence of gas after an initial warm-up delay of 5 minutes. The green LED will flash at 1 second intervals during the warm-up.

In an alarm condition:

- green LED stays on and the red LED is on
- audible alarm operates (if not disabled and after delay, if set).
- relay output activates (after a delay, if set)
- V and I output changes proportionally with gas concentration.

In a fault condition:

- green LED will be off and the red LED will be on
- voltage/current fault output will activate:
 - 2mA on the 4-20mA output
 - 0.5V on the 1-5V output
 - 1.0V on the 2-10V output.

The typical time for various sensor types to stabilize is shown below.

Sensor Type	Stabilization Time
Electrochemical (EC)	20-30 seconds
Semiconductor (SC)	1-3 minutes
Infrared (IR)	2 minutes

On power up, the electrochemical sensor outputs a signal voltage normally below the set alarm level. Semiconductors output over the + max scale, i.e., > 5V. Both move towards zero as they stabilize.

If sensors have been in long-term storage or the detectors have been turned off for a long period, stabilization is much slower. However, within 1-2 hours sensors should have dropped below the alarm level and be operational. You can monitor progress exactly by monitoring the 0-10V output. When the output settles around zero the sensor is stabilized. In exceptional circumstances the process can take up to 24 hours or more.

Section 5. Configurations

5.1. Overview

Function	Description
Time Delay	Available on the audible alarm and relay to avoid false alarms. This is set with jumpers. The default delay is 0 minutes. You may wish to set to 15 minutes during start up. See Figure 2 and Figure 3 for setting the jumpers.
Audible Alarm	The units have an internal audible alarm. You can disable this by jumper, but the default setting is “enabled” in compliance with EN378. See Figure 2 and Figure 3 for setting the jumpers.
Output	Decide which output is required: 4-20mA, 1-5V, 0-10V, relay outputs, etc. See Figure 2 and Figure 3 for setting the jumpers.

5.2. Adjusting the Alarm Set Point

This process is the same for all versions using pot P1 and test points 0V and REF1.

Step	Adjusting the Alarm Relay
1	Locate Pot P1 and use it to adjust the set point at which the relay activates.
2	Monitor the output between test points 0V (negative) and REF1 (positive) until the correct setting is reached. See example below.

Example: For a sensor range of 0-1000 ppm, calculate the voltage to set the relay at 100 ppm.

$$\text{Alarm Point Voltage} = \text{Alarm Value} \times \frac{5 \text{ V}}{\text{Max Range}}$$

$$\text{Alarm Point Voltage} = 100 \text{ ppm} \times \frac{5 \text{ V}}{1000 \text{ ppm}} = 0.5 \text{ V}$$

So the alarm voltage setting is 0.5 Volts.

Section 6. Functional Tests and Calibration

6.1. Introduction

To comply with the requirements of EN378 and the European F-GAS regulation, sensors must be tested annually. However, local regulations may specify the nature and frequency of this test.



CAUTION: Check local regulations on calibration or testing requirements.



CAUTION: The MGS contains sensitive electronic components that can be easily damaged. Do not touch nor disturb any of these components



NOTE: The MGS is calibrated at the factory. After installation, a zero adjustment maybe required due to differences in environmental conditions.



IMPORTANT: If the MGS is exposed to a large leak it should be tested to ensure correct functionality by electrically resetting the zero setting and carrying out a bump test. See procedures below.



IMPORTANT: Bacharach recommends annual checks and gas calibration. Bacharach also recommends sensor replacement every 3 years or as required. Calibration frequency may be extended based on application, but should never exceed 2 years.



IMPORTANT: In applications where life safety is critical, calibration should be done quarterly (every 3 months) or on a more frequent basis. Bacharach is not responsible for setting safety practices and policies. Safe work procedures including calibration policies are best determined by company policy, industry standards, and local codes.



IMPORTANT: Failure to test or calibrate the unit in accordance with applicable instructions and with industry guidelines may result in serious injury or death. The manufacturer is not liable for any loss, injury, or damage arising from improper testing, incorrect calibration, or inappropriate use of the unit.



IMPORTANT: Before testing the sensors on-site, the MGS must have been powered up and allowed to stabilize.

IMPORTANT: The testing and/or calibration of the unit must be carried out by a suitably qualified technician, and must be done:

- in accordance with this manual
- in compliance with locally applicable guidelines and regulations.



Suitably qualified operators of the unit should be aware of the regulations and standards set down by the industry/country for the testing or calibration of this unit. This manual is only intended as a guide and, insofar as permitted by law, the manufacturer accepts no responsibility for the calibration, testing, or operation of this unit.

The frequency and nature of testing or calibration may be determined by local regulation or standards.

EN378 and the F-GAS Regulation require an annual check in accordance with the manufacturer's recommendation.



NOTE: For improved accuracy and response, the instrument should be zeroed and calibrated in the environment in which it is being installed.

There are two concepts that need to be differentiated:

- bump test
- calibration.

<p>Bump Test</p>	<p>Exposing the sensor to a gas and observing its response to the gas. The objective is to establish if the sensor is reacting to the gas and all the sensor outputs are working correctly. There are two types of bump test.</p> <p>Quantified: A known concentration of gas is used.</p> <p>Non-Quantified: A gas of unknown concentration is used.</p>
<p>Calibration</p>	<p>Exposing the sensor to a calibration gas, setting the “zero” or standby voltage to the span/range, and checking/adjusting all the outputs, to ensure that they are activated at the specified gas concentration.</p>

CAUTION: Before you carry out the test or calibration:



- Advise occupants, plant operators, and supervisors.
- Check if the MGS is connected to external systems such as sprinkler systems, plant shut down, external sirens and beacons, ventilation, etc. and disconnect as instructed by the customer.
- Deactivate alarm delays if selected at JP5, JP6 as per Figure 2 and Figure 3.
- For bump test or calibration the MGS should be powered up for 24 hours. The instrument should be fully stabilised per Section 4.

6.2. Bump Testing

After installation, the units should be bump tested. Expose the sensors to appropriate test gas (NH₃, CO₂, etc.). The system will alarm when the test gas ppm value is above the alarm level. The gas should put the system into alarm and light the red LED. The delay prevents the audible alarm from sounding and the relay from switching (if delay is set).

With a bump test you can see the functions of the sensor - the red LED will light, the relay and audible alarm will function, and the output (0-10V, for example) will show the gas level.

Ideally bump tests are conducted on site in a clean air atmosphere.



NOTE: Prior to carrying out a bump test, check and adjust the zero setting as described in the Calibration section.



NOTE: Procedures for bump test and calibration vary depending on the sensor technology used and the gas in question. The MGS is available in three sensor versions: Semiconductor (SC), Electrochemical (EC) and Infrared (IR).



NOTE: Do not pressurize the sensor.



NOTE: For semiconductor sensors, you **MUST** use calibration gas in a balance of air (*not* N₂).



IMPORTANT: After a semiconductor or electrochemical sensor is exposed to a substantial gas leak, the sensor should be checked and replaced if necessary.

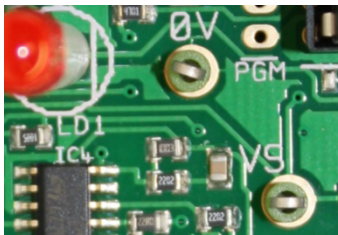

NOTE: To test the audible alarm and/or relay function, check the delay is set at zero and expose to gas. You can mute the audible alarm by removing jumper 3.

Step		Bump Testing Using Calibration Gas Cylinders
1	Remove the enclosure lid of the gas detector (not in an exhaust area).	
2	Connect a voltmeter to monitor sensor response (in Volts DC). Monitor the response between pins 0V and VS.	
3	Expose the sensor to gas from the cylinder. You can place the entire MGS into a plastic bag or use a plastic hose/hood to direct gas to the sensor head. A response of above 80% is acceptable.	

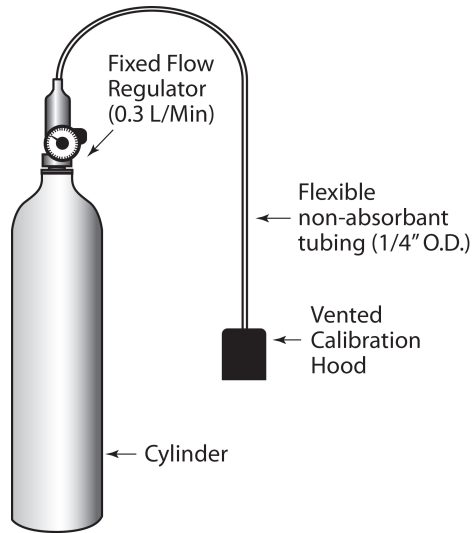

Figure 9. Gas Cylinder and Test Hardware

Gas ampoules are convenient and inexpensive alternatives to using gas cylinders for bump testing.

Step	Bump Testing Using Gas Ampoules	
1	Make sure that both the ampoules and the calibration beaker are clean and dry.	
2	Unscrew the beaker hold screw and place the ampoule so that it sits in the base of the beaker (see Figure 10).	
3	Tighten the wing-nut screw onto the ampoule without breaking it.	
4	Remove the enclosure lid of the gas detector.	
5	Connect a voltmeter between pins 0V and VS to monitor sensor response (in Volts DC).	
6	Place the beaker over the sensor head using the multi sensor adaptor to fit the sensor, or, if an Exd, IP66 or Remote sensor head version, screw the beaker on the remote sensor head M42 thread or M35 thread adaptor. It should be as tight fitting as possible to allow maximum gas exposure.	

Step	Bump Testing Using Gas Ampoules
7	Tighten the wing-nut screw onto the ampoule until it shatters allowing the gas to diffuse in the beaker. It should be left in place for approximately 5 min.
8	The voltage output will increase. This confirms that the sensor is responding. A response equivalent to at least 50% of the test gas (typical) will confirm that the system is in order if tested with the unit's specified span gas.
9	Remove the beaker from the sensor. Carefully remove any ampoule remains from the gas detector and beaker.

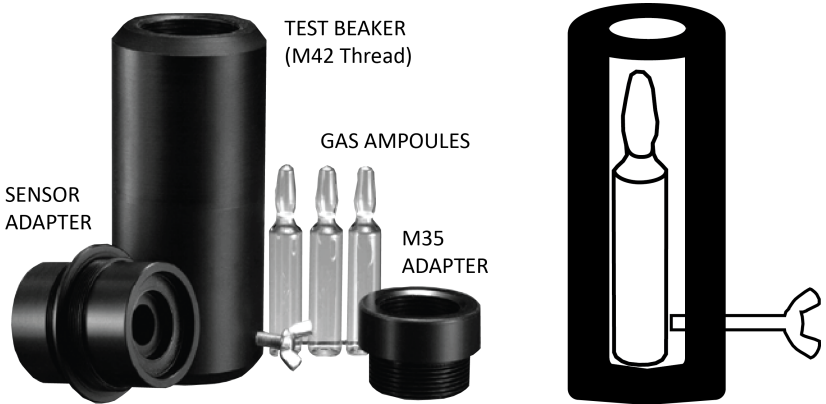

Figure 10. Gas Ampoules for Bump Testing

6.3. Calibration Overview

There are two adjustments required: zero and span. They are monitored at 0V and VS using a 0-5V scale. If the sensor range is 0-1000 ppm, then 5V=1000 ppm.

Bacharach offers a calibration kit that consists of a calibration gas cylinder, a flow regulation valve with flexible non-absorbent tubing and vented calibration hood. Tools required:

- Gas cylinder with the appropriate gas and concentration
- A voltmeter (crocodile clips recommended)
- Screwdriver (depending on housing).

The MGS has three sensor PCB versions: semiconductor (SC), electrochemical (EC), and infrared (IR).

6.4. Calculating Calibration Voltage

Sensor outputs are linear. As long as you have a gas cylinder of known concentration you can calibrate to any desired range.

Example: For a sensor range of 0-1000 ppm and a cylinder of the target gas at 800 ppm:

$$\text{Voltage} = \text{Target Gas Value} \times \frac{5 \text{ V}}{\text{Sensor Range}}$$

$$\text{Voltage} = 800 \text{ ppm} \times \frac{5 \text{ V}}{1000 \text{ ppm}} = 4 \text{ V}$$

So the output voltage signal should be adjusted to 4V.

6.5. Calibrating Semiconductor (SC) Sensors

Step	Calibrating Semiconductor (SC) Sensors
1	Locate Pot P2 which is used to adjust the zero point.
2	Monitor the output between 0V (negative) and VS (positive).
3	Adjust Pot P2 to 0 V or slightly positive (0.01 V is acceptable).
4	Locate Pot P3 which is used to calibrate the range (span) of the sensor.
5	Monitor the output between 0V (negative) and VS (positive).
6	Expose the sensor to calibration gas and allow to stabilize (approximately 6 minutes).
7	Adjust pot P3 to the voltage calculated in section 6.4 (page 29).



NOTE: For semiconductor sensors, you **MUST** use calibration gas in a balance of air (*not* N₂).

6.6. Calibrating Electrochemical (EC) Sensors

There are two adjustments required: zero and span. They are monitored at 0V and VS using a 0-5V scale. If the sensor range is 0-1000 ppm, then 5V=1000 ppm.

Step	Calibrating Electrochemical (EC) Sensors
1	Locate Pot VR201 which is used to adjust the zero point.
2	Monitor the output between 0V (negative) and VS (positive).
3	Adjust Pot VR201 to 0V or slightly positive (0.01 V is acceptable).
4	Locate Pot VR202 which is used to calibrate the range (span) of the sensor.
5	Monitor the output between 0V (negative) and VS (positive).
6	Expose the sensor to calibration gas and allow to stabilize (approximately 6 minutes).
7	Adjust pot VR202 to the voltage calculated in section 6.4 (page 29).

6.7. Calibrating Infrared (IR) Sensors

Step	Calibrating Infrared (IR) Sensors
1	Locate Pot VR203 which is used to adjust the zero point.
2	Monitor the output between 0V (negative) and VS (positive).
3	Expose the sensor to pure 99% nitrogen until output is stable (approximately 3 minutes).
4	Adjust Pot VR203 to 0 V or slightly positive (0.01 V is acceptable).
5	Locate Pot VR202 which is used to calibrate the range (span) of the sensor.
6	Monitor the output between 0V (negative) and VS (positive).
7	Expose the sensor to calibration gas and allow to stabilize (approximately 3 minutes).
8	Adjust pot VR202 to the voltage calculated in section 6.4 (page 29).

Section 7. Troubleshooting

Symptom	Possible Cause(s)
Green and Red light off	<ul style="list-style-type: none">• Check power supply. Check wiring.• MGS-150 was possibly damaged in transit. Check by installing another MGS-150 to confirm the fault.
Red light on, green led off (indicates a fault)	<ul style="list-style-type: none">• Sensor may be disconnected from printed circuit board. Check to see sensor is properly inserted into board.• The sensor has been damaged or has reached the end of life and needs to be exchanged. Contact Bacharach for instructions and support.
Alarms in the absence of a leak	<ul style="list-style-type: none">• Try setting an alarm delay.• Perform a bump test to ensure proper operation.

CE DECLARATION OF CONFORMITY

The manufacturer of the products covered by this declaration:	Bacharach, Inc. 621 Hunt Valley Circle New Kensington, PA 15068
Year conformity is declared:	2012
Product(s):	MGS
Model(s):	MGS Transmitter

The undersigned hereby declares that the above referenced products are in conformity with the provisions of the following standard(s) and is in accordance with the following directive(s).

Directive(s):

2004/108/EC	EU EMC Directive
2006/95/EC	Low Voltage Directive (LVD)

Standard(s):

Electromagnetic Compatibility (EMC) Standard	EN 50270: 2006
Safety Standard	IEC61010-1: 2010 EN61010-1: 2010

Signature:  _____

Name: Doug Keepports
Title: VP of Product Development
Date: 31 July 2013

The technical documentation file required by this directive is maintained at the corporate headquarters of Bacharach, Inc.



World Headquarters

621 Hunt Valley Circle, New Kensington, Pennsylvania 15068

Phone: 724-334-5000 • Toll Free: 1-800-736-4666 • Fax: 724-334-5001

Website: www.MyBacharach.com • E-mail: help@MyBacharach.com

